

Ergomedic 839 E



Manual
English

Contents

	3
1 Monark Exercise AB	4
2 Product Information	5
2.1 Specifications	5
3 Operation Instruction	6
3.1 Operate the ergometer	6
3.2 RPM Display and Visual Metronome/Pulse	6
3.3 Cycle adjustments	6
3.4 Where to obtain additional information	7
3.5 Warranty	7
3.6 Final assembly instructions	7
3.7 Initial operation	7
4 Connection to controller	8
4.1 Connection to PC	8
4.2 Connection to an external ECG device, digital control	9
4.3 Printer	9
4.4 Analog control	9
5 Calibration	10
5.1 Validation	10
5.2 Force	10
5.3 Calibration electronics	11
5.4 Power on crank or flywheel	11
6 Testing with Ergomedic 839 E	12
6.1 Heart rate (Telemetry system)	12
6.2 Subject supervision	12
6.3 Reviewing results	13
7 Computer Reference	14
7.1 Description of the terminal	14
7.2 Menu 1: Fitness test	19
7.3 Menu 2: Manual/ Work test	23
7.4 Menu 3: Sequence programs (user defined protocols)	25
7.5 Menu 4: Analog control	26
7.6 Menu 5: Calibration	26
7.7 Menu 6: System	27
7.8 Menu 99: Service menu (hidden)	28
8 Service	31
8.1 Service check & maintenance	31
8.2 Transport	31
8.3 Calibration of pendulum weight	32
8.4 Zero adjustment of meter panel	32
8.5 Brake belt contact surface	33
8.6 Replacement of brake belt	33
8.7 Pendulum weight bearing	33
8.8 Chain 1/2" x 1/8"	34
8.9 Crank bearing	34
8.10 Freewheel sprocket	35
8.11 Flywheel bearing	35
9 Spare parts	36
10 Appendix	38
10.1 Operation interferences	38
10.2 Trouble shooting guide	38
10.3 Error messages	39
10.4 References	39

2 Product Information

Congratulations on your new Ergometer.

Monark Ergomedic 839 E is one of the world's most precise and user-friendly computerized pendulum ergometers.

The Ergometer is controlled by either a control unit, an external PC or other external units. The bike can perform max and submax fitness tests and calculate the VO₂ max. The ergometer can be connected to ECG to do work tests.

It is possible to build personal programs that are custom made for the user. The bike can also be used for manual training.

NOTE!

The use of Ergomedic 839 E can be physically strenuous. Always consult a doctor before beginning an exercise program and stop immediately if feeling faint or dizzy.

2.1 Specifications

Construction:

- Large, well balanced flywheel, 22 kg
- Brake power 0-1400 W at 200 RPM
- Pendulum scale, easy to calibrate
- Comfortable saddle with adjustable height
- Handlebars with adjustable height and distance from seat
- Stable, heavy duty steel frame
- Powder painted
- Wheels for easy transport

Computer:

- Computer system 8MHz
- Multi-colour RPM pacing bar graph display
- Visual metronome or heart rate
- Serial communication port: 300 - 38400 baud
- HR-training

Electrical:

- Voltage 24 VDC or 18 VAC.
- Transformer to wall outlet. 100 - 240 VAC, 50/60 Hz, 15 W. Note: The transformer must be approved by your national electrical authorities.

Measured quantities:

- Distance: meter, miles
- Energi: kcal
- Heart rate: beats/minute(bpm)
- Force: Newton(N)

- Power: Watts(W), kpm/min or VO₂ ml/min/kg
- Time: min, sec
- Weight: kilogram(kg), pounds(lb)

Dimensions:

- Length: 1120 mm (44")
- Width: 530 mm (21")
- Height, handlebar: 650-1135 mm (30"-45")
- Height, saddle: 800-1120 mm (31,5"-44")
- Weight: 55 kg (112 lbs)



Certificate
CE 93/42
ISO-9001

3 Operation Instruction

3.1 Operate the ergometer

Ergomedic 839 E is built on a stabile frame, a large well balanced flywheel, a break belt and a pendulum weight which measure the force. Pedals and a chain drive are provided to spin the flywheel as a tension device tightens the belt to regulate the braking force applied to the wheel. The pendulum indicates the applied force directly on the scale located on the right side of the flywheel.

The computer system consists of one main unit and one control unit (terminal, PC or ECG). The main unit reads in the pedal speed, the applied force and determines the subjects heart rate by a chest transmitter. Additionally, the base controller activates motor to adjust the tension of the belt, thereby regulating the applied braking force. The force may be automatically varied in response to changes in pedal speed to maintain a constant power workload.

For information about how respective control unit works, see "Connection to controller".

3.2 RPM Display and Visual Metronome/Pulse

The metronome (the two green LED bars in the middle) flashes once per pedal stroke at a preset rate. The two green LED bars in the middle can also be set to show pulse. It makes one flash for every heart beat. Pedal frequency compared to metronome rate is always shown.

Underspeed:

Pedal speed is lower than desired metronome rate. 2, 4, 8, 16 or more depending which LED bar that indicates.

Overspeed:

Pedal speed is greater than desired metronome rate. 2, 4, 8, 16 or more depending which LED bar that indicates.

3.3 Cycle adjustments

Seat height should be adjusted to a comfortable position. A suitable height is when your knee is slightly bent and the middle of the foot is straight above the pedal axle with the pedal in its lowest position. To adjust the seat height loosen the lever on the seat tube. See *fig: Adjustments*.

The handlebar setting should give a comfortable position when cycling. During longer exercise sessions it is recommended that you occasionally change the handlebar position. To adjust the handlebar loosen the quick release lever. See *fig: Adjustments*.

NOTE! The handlebar stem should be inserted into the frame tube at least 3 inches (about 8 cm). this measure is marked out on the stem(3).

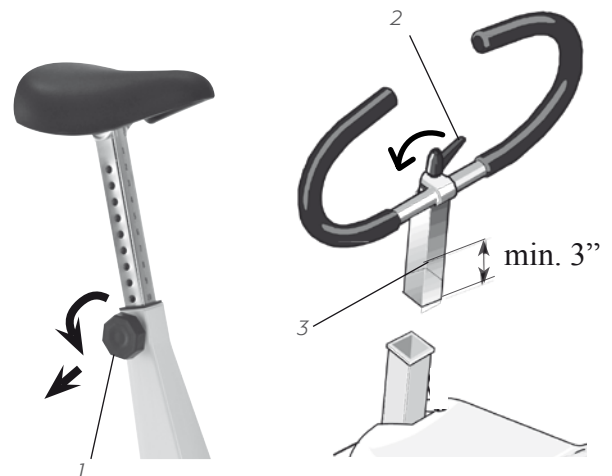

Fig: Adjustments
 1) Lever, seat post
 2) Lever, handlebar
 3) Inserted min. 3"

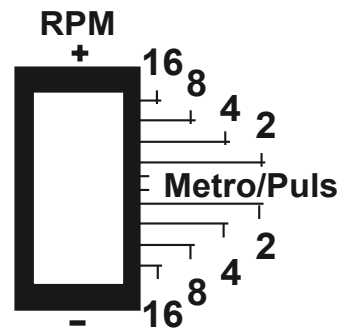

Fig: RPM display

3.4 Where to obtain additional information

The user may require more information concerning several areas of the ergometer usage. This manual was intended to instruct the reader primarily in the operation of the ergometer. Reference are made to related topics in the discussions concerning the testing procedures and the protocol operation sections. The following readings may provide some greater insight to ergometer based testing without confusing the reader with extremely technical medical terms. Both texts were written specifically to provide basic understanding of the testing methodology and results. Attention is paid to details concerning program setup and management.

- Golding LA, Myers CR, Sinning WE, "The y's way to physical fitness", YMCA of the USA, Rosemont, IL, 1982 .
- Astrand P-O, "Work Tests with the Bicycle Ergometer", Monark AB, Varberg, Sweden.

For more technical details, see the section entitled "Appendix: Reference".

3.5 Warranty

EU countries private use

If you are a natural person you will have a minimum level of protection against defects in accordance with EC Directive 1999/44/EC.

In short, the directive provides for that your Monark Dealer will be liable for any defects, which existed at the time of delivery. In case of defects, you will be entitled to have the defect remedied within a reasonable time, free of charge, by repair or replacement.

EU countries professional use

Monark products and parts are guaranteed against defects in materials and workmanship for a period of one year from the initial date of purchase of the unit.

In the event of a defect in material or workmanship during that period above, Monark Exercise will repair or replace (at its option) the product. Monark Exercise will do so at its expense for the cost of materials but not for labor or shipping.

Other countries

Monark products and parts are guaranteed against defects in materials and workmanship for a period of one year from the initial date of purchase of the unit. In the event of a defect in material or workmanship during that period above, Monark Exercise will repair or replace (at its option) the product. Monark Exercise will do so at its expense for the cost of materials but not for labor or shipping.



Fig: Serial number (1)

Please note: The production number of your Ergometer is placed according to fig: Serial number.

3.6 Final assembly instructions

Read these instructions prior to assembling the ergometer! Assemble the supporting legs, pedals, saddle and handlebar as specified in the "Quick guide". Remember to remove the transport tape on the pendulum.

3.7 Initial operation

Although all 839 ergometers are 100% calibrated at the factory, the user may wish to verify this by performing the mechanical calibration of the pendulum weight. See section "Calibration of Pendulum Weight".

Apply power to the ergometer by first connecting the cable from the transformer to the ergometer at the front connector labeled "24VAC/18VAC". Then plug the transformer into the wall outlet. Turn the power switch to on position. A green LED indicates power to the 839.

Perform the electrical calibration as specified in section "Calibration Electronics".

Test ride the ergometer. The 839 Electronic Ergometer is now fully functional and ready.

4 Connection to controller

The Monark Ergometer 839E can be controlled externally from a terminal, a computer or a ECG. A printer can also be connected to the ergometer.

The control is performed over a serial line using ANSI/ISO/ASCII format commands. The interface is a 9 pin male D-sub connector, compatible with the RS232 standard, located on the front of the electronic. To connect to a PC use a 0-modem serial cable with 9 pin female connectors in both ends.

It is also possible to use a analog control from an external source to set the workload. This is done by the contacts b32 and z32 on the main connector on the bike.

The ergometer need not be turned off prior to connection of the external components, although removing the power from all devices may prevent erroneous data transfer between equipment during interconnection. Caution must be exercised in the connection of various types of equipment from different manufactures to avoid electrical hazards and physical damage. The user must be certain that the instrument connector and the cable are designed for the intended purpose. Serious injury to the user and/or equipment may result if inappropriate connections are attempted.

For a complete description of the command interface setup order the Technical Manual for Monark 839E, from Monark Exercise AB, Sweden.

4.1 Connection to PC

To connect a PC to the ergometer, use a 0-modem cable (RS232) with a 9-pin D-sub female at each end. If no RS232 Serial port is available on the computer use a USB serial RS232 converter.

To control the ergometer use the PC software supplied with the ergometer or other PC software made for the Ergomedic 839 E.

From software version MEC3V11R14 and later settings can be made from a PC in terminal mode if the handheld terminal is not available.

Do as follows:

1. Set PC in terminal mode. A terminal emulator is normally available in i.e. Windows under Accessories/Communication.
2. If no RS232 serial port is available on the PC use a USB serial converter to connect to a USB port.
3. In terminal mode do the following settings:
 - 9600 baud
 - 8 data bit
 - 1 stop bit
 - no parity
 - no flow control
 - set terminal emulation to VT100
 - set the com port number.

A USB serial converter is automatically assigned to a com port number by Windows.

4. Connect Ergometer and PC with the 0-modem cable (normally used for the ergometer handheld terminal).
5. Turn on power to the ergometer. The ergometer is now checking what type of device is connected. When finished a message appears on the PC screen. Common commands:
 - Calibration: Type: cali[enter] and follow the instructions on the screen.
 - Setting to control ergometer from an external Siemens Megacart ECG device:
Type: env cmdtype=1[enter]
 - Setting to control ergometer from other external ECG devices:
(most common setting)
type: env cmdtype=2[enter]
6. To go back to control the ergometer with the handheld terminal. Type: env cmdtype=[enter] or env cmdtype=0[enter]

A lot of other settings can be made. For more information about this please see Technical Reference Manual MEC3V11Rn.

4.2 Connection to an external ECG device, digital control

7. Connect the handheld unit to the main unit on the front of the bike (use the 0-modem cable with a 9-pin D-sub female at each end).
8. Connect the net adaptor to a suitable wall outlet and to the Monark Ergometer 839 and then turn power on.
9. After a short while the main menu is shown on the handheld display.
10. Press '99' and the service menu comes up on the display.
11. Press '6' for Service setup.
12. Press 'Enter' on the following settings until 'Command Type' is shown.
13. This says:
 - 0 Terminal/PC
 - 1-3 see manual
 - (0) _
 If a zero (0) is displayed at the 3rd line, the bicycle is in normal mode which means that the bike can not be controlled by an external ECG device. Press '1' if a Siemens Megacart with Ergomed 940 will be used. For use of other devices press '2' or '3' and then 'Enter'. If correct figure is displayed from the beginning just press 'Enter'.
14. Return to main menu by pressing '0' and press '0' again to finish. The computer will then save the settings in the memory before it turns off. Computer will start up again automatically after a few seconds.
15. Turn off the power and remove the handheld unit.
16. Connect the cable (Megacart needs a specific cable) into the ECG device.'

The Ergometer can now be controlled only from an external ECG device.

Reset of the Ergometer to normal mode (controlled from a handheld unit).

Follow steps 1 – 7. At step 7 press '0' and then 'Enter'. The Ergometer can now be controlled again from the handheld unit or an external PC.

4.3 Printer

The 839 Electronic Ergometer interfaces to several optional devices. A parallel interfaced printer may be attached to provide written reports.

The terminal or the computer attaches both via a serial cable to the 9 pin interface connector located on the front of the ergometer. Attach a printer if available to the parallel port on the front.

If the instrument is a terminal or printer, the system may need to be setup. Verify that the System setup have been set to enable automatic printout. If it has been disabled, no output will reach the device until it has been enabled. Also, the baud rate selected by the interface cable must match that of the device. If the device is a printer, proper paper loading and unit selection must be completed prior to operation (refer to printer instruction manual).

The automatic printout length is a preset to eleven inch pages for standard fanfold or zee-fold paper. At the top of the each page, a header designating the columns is printed.

The time period between the printing of each line may be set as desired, from 0 (continuous output) to 255 seconds in one second increments. The standard setting is 15 seconds between printouts. This provides reasonable documentation while not wasting large quantities of paper.

4.4 Analog control

Please see chapter 7.5 Menu 4: Analog control.

5 Calibration

The 839 E is a mechanically weighted and braked ergometer, making performance validation a simple procedure. The work performed on the ergometer is the product of the weight lifted times the numbers of revolutions (factored). Validation includes both mechanical and electronic procedures. If the ergometer fails to pass any section of the validation, proceed to the calibration and/or service menu (99 in the main menu).

Inspection of all mechanical components is suggested after any repair, or component service. Once per year, the following validation should be performed.

1. Remove the cover from the flywheel.
2. Loosen the brake belt at the balancing spring.
3. Wait until the flywheel is not moving any longer.
4. The pendulum weight index should be aligned with "0" on the scale.
5. Attach the calibration weight to the point at which the spring was attached.
6. The known weight should match the value on the scale. If not see section "Calibration of Pendulum Weight".
7. Reattach the tension belt.
8. Reassemble the cover.

Proceed to the validation to complete.

5.1 Validation

The following procedure will assure the user that the ergometer is performing properly on a daily basis. The test exercises the mechanical braking, pedaling and speed detecting systems as well as the computer regulation and sensing capability of the mechanical system.

Additionally, if a calibrated ECG simulator is available, it may be used to verify the heart rate measuring system. Whether the simulator is used or not, the heart rate system may be validated by simply taking a pulse point rate measurement at the neck for example. While a patient is at rest and has been prepared for chest belt electrodes or an ear sensor, the pulse indicator flashes once per pulse beat. The displayed rate, should agree with

the manually detected pulse rate. If not, check the patient electrode connection and skin preparation prior to requesting service.

5.2 Force

From main menu go to any start display with newtons (N).

1. With the pendulum at zero, the display should read "0".
2. Move the pendulum weight to the 4 kp position and the display should read "39" Newtons.
3. Decrease the position of the weight by steps of 1 kp. The display should read correctly at all positions.

NB: After this check the brake belt will be somewhat loose and because of this it will take a few seconds before normal workload is obtained the first time the ergometer is used.

Power:

Power calculation

1 rpm = 6 m on the flywheel brake surface.

50 rpm = 300 m

2 kp force makes $2 \times 300 = 600$ kpm/min

100 rpm = 600 m

1 kp force makes $1 \times 600 = 600$ kpm/min

(watt = RPM x kp)

5.3 Calibration electronics

Calibration is necessary to match the mechanics of the ergometer to the electronics of the computer. The following steps are required to recalibrate the electronics to the pendulum scale.

1. Check at the bottom of the flywheel that the brake belt is loose. If not move the pendulum up to 3 kp and hold it for a few seconds. Move the pendulum to the zero position again. Check that the brake belt is loose.
2. Align the force scale with zero marker on the pendulum. Refer to section "Zero adjustment of meter panel" for details.
3. Press key 5 in the main menu (Calibration) and follow the display instructions. Hold the pendulum at 0-position and wait for one "beep".
4. Hold the pendulum at 2 kp-position and wait for one "beep". Hold the pendulum at 4 kp-position and wait for one "beep". Move the pendulum to the 6 kp position as told in the display. Hold it in position and wait for two "beeps" shortly after each other.
5. Lower the pendulum to the resting position (0-marking). Calibration is done.

The calibration coefficient which has been calculated by the computer is stored in the continuous memory. Whenever power is applied to the ergometer, the latest calibration value is restored to maintain memory. A new calibration replaces previous values.

Generally, it is not necessary to recalibrate the ergometer often. The coefficient is maintained even when power is removed and the physical orientation of the frame, within the limits of normal riding, has no effect on the electrical calibration. Recalibration should be performed following any service, component replacement, or transport of the unit or after setting to default in the service menu(99).

A daily validation of the pendulum force sensor should be performed. If the procedure reveals an error, recalibration may be necessary.

Check of the electronic calibration can be done as follows;

From main menu go to any of the test displays shoeing newtons (N). Move the pendulum to 4 kp(39N). This position shall now be read in the display. If not perform a new calibration.

NOTE!

After this check the brake belt will be loose, which means that the first time the ergometer is used after calibration it will take a few seconds before normal workload is obtained.

5.4 Power on crank or flywheel

839 Ergometer adapted to ECG-work tests is set to measure the power on the crank.

839 Ergometer adapted to fitness tests is set to measure the power on the flywheel.

A sticker, placed on the head tube, see *fig: EKG-sticker*, informs that the ergometer is set to measure the power on the crank.



Fig: EKG-sticker

6 Testing with Ergomedic 839 E

The versatility of the 839 Electronic Ergometer enable it to be utilized in a variety of testing environments. The precision and reproducibility of measurements made with the ergometer in conjunction with the ease of testing, allow it to be employed in clinical exercise stress facilities, corporate fitness programs and health clubs. The backgrounds of both the individuals being tested and those administering the test may be vastly different in these widely varying testing situations.

In general, whether in a clinical laboratory or a health club, the subject may be exercised quite strenuously, depending on workloads which have been selected. As a precaution, it may be advisable, prior to beginning an exercise protocol, that each subject consult with a physician. Before testing, the operator should review the entire protocol operation with the subject, explaining the work which will be required and the duration of the procedure. A system of communicating fatigue, chest pain or other abnormal physical response to the exercise should be discussed.

The subject should not engage in heavy physical activity for several hours prior to testing to establish maximum oxygen consumption. In addition, all testing and exercise protocols should be performed a reasonable time after meals. The subject should also refrain from smoking within an hour of the testing period.

The subject should not be prepared for riding the ergometer, including the selection of proper clothing which neither interferes with the physical activity nor endangers the health of the subject. The subject may need some general education concerning the pedaling of the ergometer. The saddle and the handlebars should be adjusted for comfort and proper mechanical distance. The saddle height should be set so that when the ball of the subject's foot is placed on the pedal, there is a slight bend at the knee with the pedal in the lowest position.

The operation of the speed metronome and over/under display should be reviewed. The maintenance of the proper speed should be practiced at a low workload.

Finally, the chest belt should be applied and monitored to check for proper heart rate operation. The baseline heart rate may also be of assistance in determining the nervousness of the subject. The subject should exhibit a relatively stable resting heart rate prior to starting the protocol.

6.1 Heart rate (Telemetry system)

The subject's heart rate can be monitored by chest belt telemetry system. The system with chest belt electrodes is standard equipment.

The chest belt should be secured at a comfortable tension around the mid section, just below the breasts. Moisten the electrodes before use. Heart rate monitoring, free from artifact, requires good electrode contacts and adequate skin preparation. Prior to placing the electrodes, the subjects skin, at the electrodes sites, should be cleaned with one of the commercial skin prep solution. To make sure that you have found the correct position the logo should have been placed in the center of chest and also be readable for another person. To enable a reliable contact with pulse receiver on the bike the distance should be kept below 100 cm. It is important to identify the chest belt with the pulse receiver by standing close to it before beginning (max 60 cm, concerns Polar belts). After the chest belt is placed the heart rate will be displayed and the heart will verify each beat. If the RPM bar is set to show optical heart beat in the middle section this will also verify each heart beat.

NOTE! Electromagnetic waves can interfere the telemetry system. Cellular phones are not allowed to be used near the bike during test.

If the ergometer is to be used without chestbelt note that max heart alarm should be set in off position so that external noise not can cause a random max pulse or higher. This switch is in on position by default. If the heart rate exceeds the maximum level set, the alarm will sound and the ergometer braking force will decrease until the heart rate drops below the alarm level.

6.2 Subject supervision

The ergometer performs automated tests virtually by itself, requiring minimal intervention by the operator. This allows the operator to pay careful

attention to the subject without distraction. The response to the exercise protocol can be accurately estimated and appropriate action to assist the subject, if necessary, may be given. The rider is subjected to considerable exercise in certain advanced protocol stages. The effect on the subject should not be underestimated.

During the testing, the general appearance and heart rate may be the most crucial factors to monitor. The testing should be stopped immediately if the subject reports chest pain, difficulty breathing, etc. A system of prompt medical attention should be set up prior to testing, in case of emergency.

The subject may also show difficulty in regulating the speed of the ergometer. The power will be properly regulated regardless of the speed, assuming that the protocol work type is not force and that the speed is maintained above the pedal low setting (default is 30 RPM).

In addition, some subjects may become sensitive to the display on the handheld remote controller. If this is suspected, the controller may be removed from its cradle and located out of view. Similarly, the pulse LED may disturb the subject and may be disabled.

6.3 Reviewing results

The maximum oxygen uptake is the standard measurement of cardiopulmonary fitness. Dependent on the linear relationship between work and oxygen uptake and between work and heart rate,

the heart rate response to work may be used to estimate the oxygen consumption. If the maximum heart rate is considered, the maximum oxygen consumption may be determined.

The YMCA and Astrand protocols estimate the maximum oxygen consumption, based on a sub-maximal workload while all others report the oxygen consumption required by the final workload. The Bruce and Naughton protocols require that the subject exercise at a workload level for a minimum of one minute to establish the oxygen consumption; If less than one minute is observed, The previous workload value is used.

The estimated maximum oxygen consumption derived from some of the ergometer tests is subject to the error of the “age related predicted maximum heart rate“. Although there is a definite and linear relationship between work and oxygen uptake, there are some differences in actual oxygen uptake based on individual work efficiency. Subject who are less familiar with bicycle exercise and those individuals who are less fit, are more likely to be less efficient than those who ride bicycles frequently.

It should be noted that these results are estimates or predictions of maximal response and have a greater chance of being in error than if the individual were tested to their actual maximum value. Interpretation should therefore be made more carefully with an understanding of the possibility of errors in the methodology.

A relative fitness index can be obtained from the following tables:

<i>Fitness Rating Index - Males</i>				<i>Fitness Rating Index - Females</i>			
<i>Maximum Oxygen Consumption ml/kg/min</i>				<i>Maximum Oxygen Consumption ml/kg/min</i>			
<i>Rating</i>				<i>Rating</i>			
	<i>-36 yrs</i>	<i>36-45 yrs</i>	<i>45- yrs</i>		<i>-36 yrs</i>	<i>36-45 yrs</i>	<i>45- yrs</i>
<i>Excellent</i>	54	53	43	<i>Excellent</i>	55	49	46
<i>Good</i>	49	45	38	<i>Good</i>	45	43	38
<i>Above Av.</i>	46	39	34	<i>Above Av.</i>	39	37	32
<i>Average</i>	36	33	30	<i>Average</i>	34	33	27
<i>Below Av.</i>	32	29	27	<i>Below Av.</i>	30	29	24
<i>Fair</i>	28	25	24	<i>Fair</i>	26	26	20
<i>Poor</i>	24	23	20	<i>Poor</i>	20	22	18

See also table 7 in “Work tests with the Bicycle Ergometer“ by P O Astrand.

7 Computer Reference

7.1 Description of the terminal

The Monark Ergometer 839E can be controlled externally from a terminal, a computer or a ECG. This chapter describes the terminal.

7.1.1 Display

Options on the display;

- 1 Fitness test
- 2 Man./Work test
- 3 Seq.programs
- 4 Analog control
- 5 Calibration
- 6 System
- 0 Exit

7.1.2 Keyboard layout

Used keys:

Key 1 - 9: menu choice and numeric input

Arrow key up/down: scroll function

Dot key: decimal input

Del.key: delete function

Enter: enters input

Special function during fixed protocols:

Key 9: increase step on force/power level

Key 6: decrease step on force/power level

Key 3: start/stop program

Key 7 8 9: increase level

Key 4 5 6: decrease level

7.1.3 Ergometer continuous memory

To ease operation of the ergo meter, several “variables” are stored in “nonvolatile memory”.

These variables are restored to normal memory each time power is applied to the ergometer.



- 1 Fitness test
- 2 Man./Work test
- 3 Seq.programs
- 4 Analog control

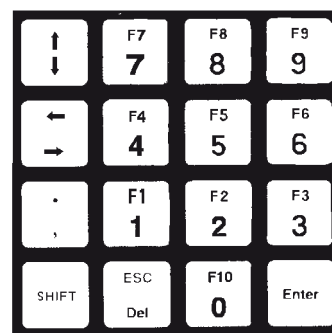

7.1.4 Printer report

If a parallel printer (DOS compatible) is connected to the Ergometer a hard copy test report may be obtained, documenting the protocol progress at preset time intervals. At the end of a fixed protocol, a calculation is prepared.

NOTE!

The auto printout function must be enabled for the printer to operate outside fixed protocols. To change the time interval between successive printouts, see System menu.

Sample Report:

Monark Ergometer 839E. Åstrand - Report: xx Page: 1

Name:

Test:

Date:

Sign:

Age: 43 years Weight: 82.0 kg Sex: Male

Max. Heart Rate(bpm):177

Time	RPM	BPM	N	kcal	km/h	km	Ref.
00:30	64	82	04	01.0	23.1	0.2	1500kpm/min
01:00	64	107	38	08.0	23.1	0.4	1500kpm/min
01:30	57	127	43	16.0	20.4	0.6	1500kpm/min
02:00	53	139	46	25.0	19.1	0.8	1500kpm/min
02:30	52	143	47	33.0	18.7	1.0	1500kpm/min
03:00	53	151	48	41.0	19.1	1.1	1500kpm/min
03:30	53	150	46	50.0	19.1	1.3	1500kpm/min
04:00	51	153	48	58.0	18.3	1.4	1500kpm/min
04:30	52	154	48	67.0	19.8	1.6	1500kpm/min
05:00	53	155	46	75.0	19.0	1.7	1500kpm/min
05:30	54	157	46	83.0	19.5	1.8	1500kpm/min
06:00	57	156	43	92.0	20.4	2.0	1500kpm/min

Measured heart rate (BPM) : 156

Calculated maximum V02: Max: 49.4 ml/kg/min 4.05 l/min

7.1.5 Protocol operation

A protocol operation cycles the ergometer through a predefined workload sequence, automatically. The protocol may be designed to alter the workload according to time or a physiological response such as heart rate. Several of the protocols may be modified or customized by the user to suit specific needs.

The programmed sequence of workload may be set to provide a varying workload. The rate of change of the workload may be specifically set in some protocols. Still other protocols may exercise the subject to a maximum (or submaximal) effort to determine an index of fitness (oxygen consumption).

A protocol may terminate based on the passage of time or the satisfaction of a specific physiological conditions such as a "steady state" heart rate. For details, refer to the specific protocol operation description.

At the conclusion of a protocol, a summary is printed, if the optional external printer is installed. This report includes various identification data: the protocol name, the subjects age, weight, sex. In addition, test results are printed, including the predicted maximum heart rate, the actual steady state heart rate, the maximum workload and the "V02 max". The V02 maximum is expressed both as a total body usage in l/minute and per kg of body weight in ml/kg/minute. If a printer is not available, only the V02 max data, both in l/min and ml/kg/min are displayed. The interpretation and meaning of the V02 max data is specific to the design of the particular protocol. Certain protocols are simply programmed exercise and therefore are not designed to measure V02. Please refer to the specific protocol description prior to attaching any significance to the reported value.

The computer controller for the 839 Ergometer can perform different protocols in addition to strict manual operation. Four protocols have been preset and 2 are partly preset. Several preprogrammed protocols measure oxygen consumption at steady state: the Astrand, using a single workload, the YMCA, using multiple branching workloads ("YMCAs Way to Physical Fitness"

bicycle test) and the Bruce and Naughton, using multiple increasing workloads (treadmill protocols adapted to bicycles ergometry). Additional preprogrammed protocols, not designed to measure V02, provide timed increasing workloads (ramp and incremental) and a heart rate training program in which a target heart rate is set and the ergometer attempts to maintain the target rate by varying the applied workload accordingly.

All protocol operations enable the heart alarm feature. The alarm value is preset to 220 - age. During the test setup procedure, the maximum heart rate may be changed depending on the subjects exercise prescription or other constraints.

If the heart rate exceeds the alarm value, a beeping tone will be heard until the heart rate falls below the alarm point or the alarm is disabled. When the alarm sounds, the workload is removed, automatically, to prevent overstressing the subject.

The alarm feature may be disabled, particularly if the protocol does not require monitoring of the subject's heart rate. If heart rate is not being monitored, start the protocol and then disable the alarm.

The automatic protocol attempt to exercise the subject at specific oxygen consumption levels. The ergometer achieves this by producing a braking force which, in normal individuals, requires the consumption of the desired volume of oxygen. Note that most protocols express the V02 in ml/kg/min, therefore, the total V02 required is calculated using the subjects weight and subsequently converted to a power workload. The table below shows the nominal work equivalent to various oxygen consumption rates.

<i>Work load (Kpm/min)</i>	<i>Oxygen uptake (L/min)</i>
300	0,9
600	1,5
900	2,1
1200	2,8
1500	3,5
1800	4,2
2100	5,0
2400	5,7

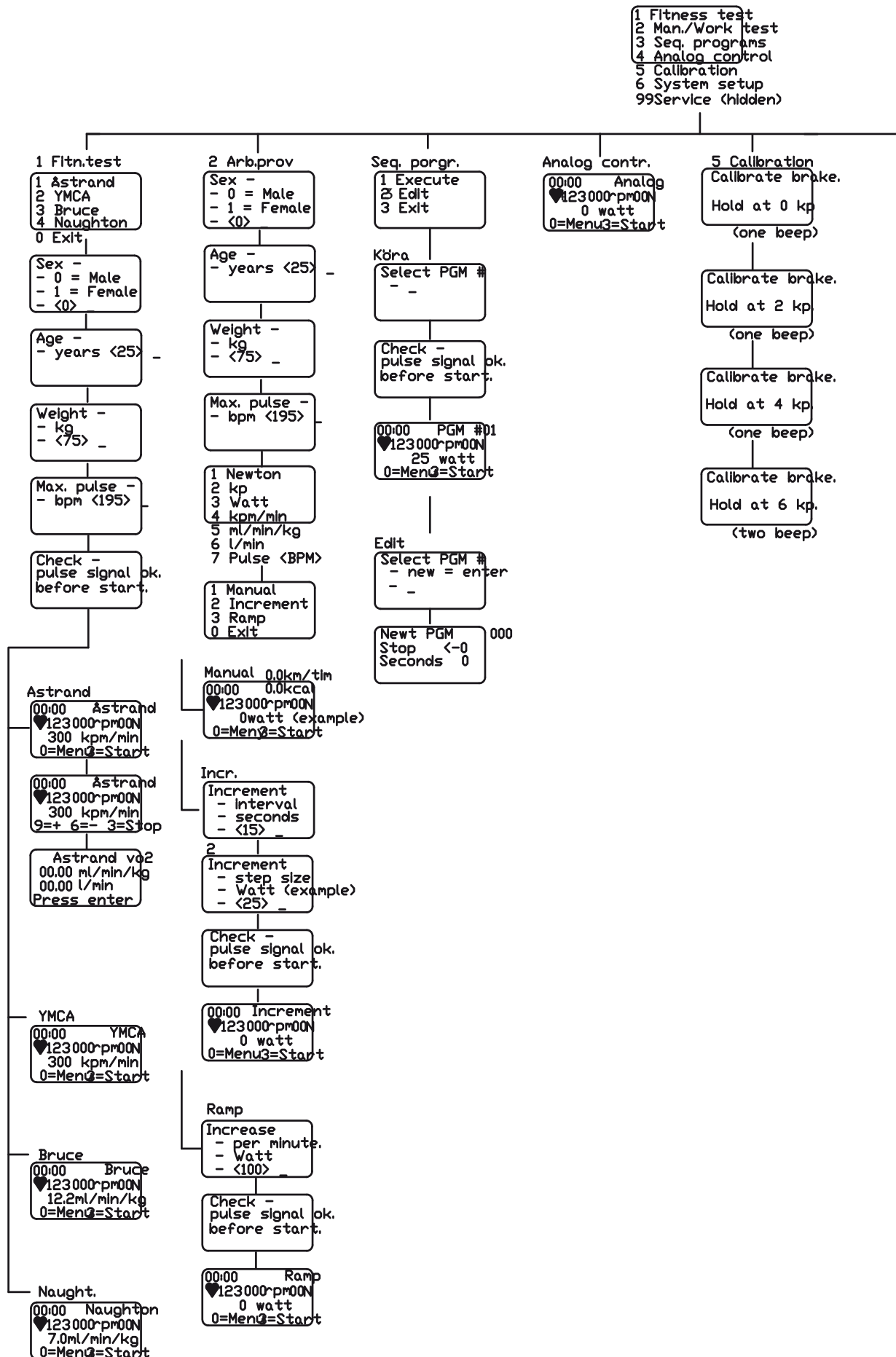

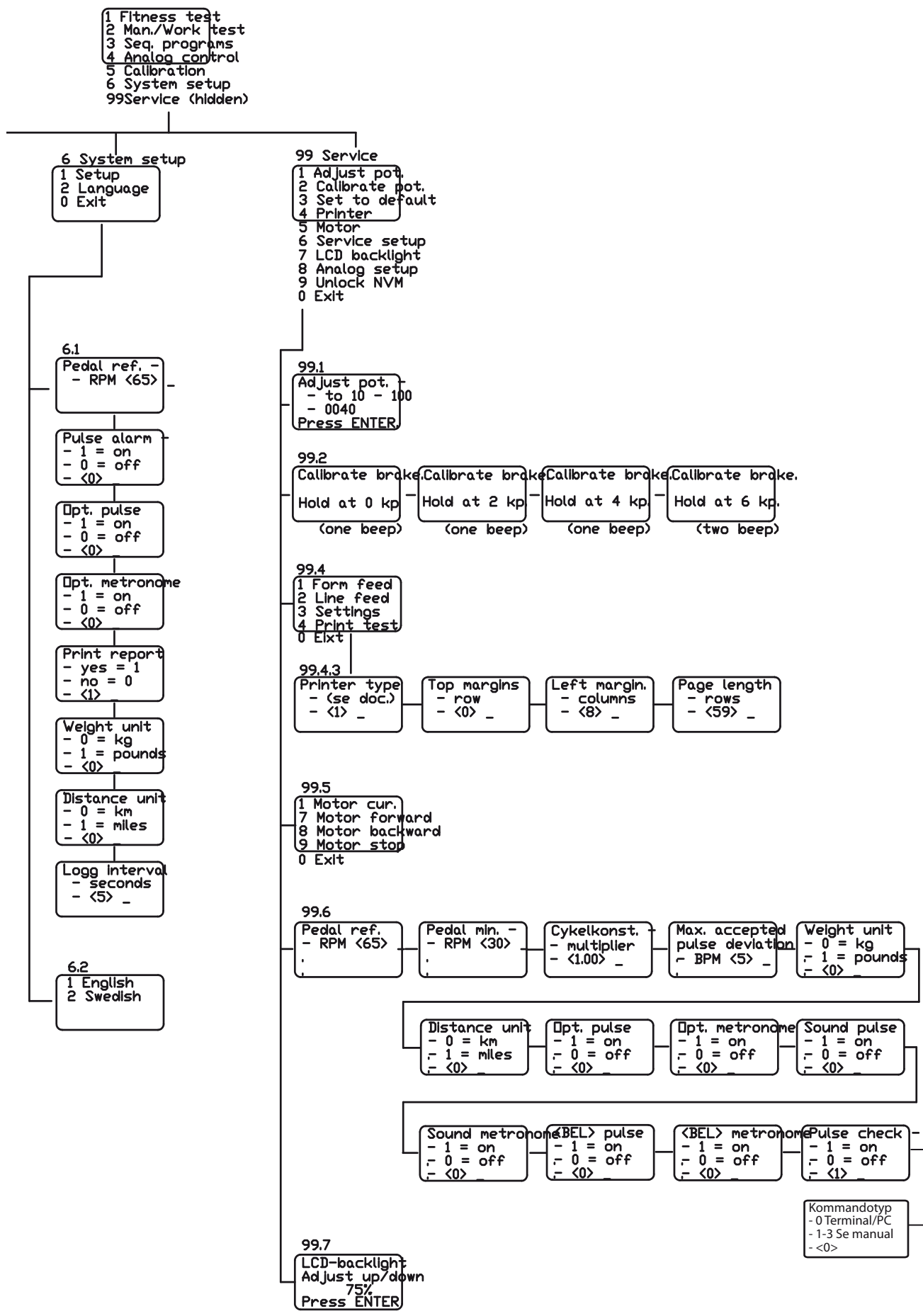

7.2 Menu 1: Fitness test

7.2.1 Åstrand - Protocol

The Åstrand protocol is designed to determine maximal oxygen consumption by exercising the subject at a submaximal workload and measuring the steady state heart rate. The workload, in conjunction with the resultant heart rate, is compared to the predicted relationship, adjusted for age and sex and a maximal oxygen consumption is computed.

The protocol defines nine workloads at which the subject may be evaluated. The workloads for male subjects span 300 kpm/min to 1500 kpm/min in 150 kpm/min steps. The workloads for females cover 300 kpm/min to 900 kpm/min in 75 kpm/min steps.

The workload selection is performed manually during the first two minutes of the test. The workload should be difficult enough to elicit a steady heart rate of at least 120 bpm. If too high a workload is chosen, the subject may not be able to complete the minimum of six minutes necessary to reach steady state conditions. The protocol has been designed to test individuals with a normal mechanical efficiency during steady state; very high workloads can only be performed aerobically by individuals with a very high work capacity.

During the workload selection interval, the workload should be increased until the heart rate varies no more than 4bpm and is consistently greater than 120 bpm.

At the end of the fifth minute, the heart rate is recorded. If, by the end of the next minute, the heart rate is within 4 bpm of the previous observations, the protocol is finished. If not, the test continues until the pulse rate has been within 4 beats for one minute. Note: If the heart rate is erratic or the workload is improperly adjusted for steady state exercise, the test will fail to complete. Of course, the protocol may be interrupted by the START/STOP key, although the error message "Test Aborted" and no calculation of V02 max will result.

The maximum oxygen consumption is obtained through the look up of the steady state heart rate and workload in the appropriate male or female table of "Predicted V02 Max from Heart Rate and Workload". This estimate is then multiplied by a factor which is related to the age of the subject. The factor is found in the following table according to the predicted maximum heart rate:

V02 Correction Factor	
Maxpuls	Factor
<i>over 200</i>	<i>1.12</i>
<i>191-200</i>	<i>1.00</i>
<i>181-190</i>	<i>0.93</i>
<i>171-180</i>	<i>0.83</i>
<i>161-170</i>	<i>0.75</i>
<i>151-160</i>	<i>0.69</i>
<i>less than 151</i>	<i>0.64</i>

Performance:

- Instruct subject about the protocol and adjust the chest belt for reliable pulse.
- Setup subject data according to the menu. See menu Åstrand test.
- Select ÅSTRAND and push key 3 = start.

7.2.2 YMCA protocol "Y's way to physical fitness"

The YMCA protocol is based on the "Y's Way to Physical Fitness" bicycle test. The design is a submaximal test, using branching multiple workloads in which the next workload is determined by the steady state heart rate elicited by the previous level. For details, refer to the "Workload Branching" tables, later in this section.

Every three minutes the workload is advanced until the subject has completed three levels, requiring a total of nine minutes. If the subject has an abnormally high heart rate response to the initial workload (100 bpm or more), the test is terminated at the end of the second level. If the operator senses that the subject is experiencing difficulty completing the third level of the protocol, the START/STOP key may be used to conclude the test early. If the test is stopped prior to the completion of the second level, an error message is displayed, indicating that the test was "aborted" and no calculation of V02 max is possible.

At the conclusion of the test, estimates of the V02 max and the maximum workload are extrapolated from the data collected during the previous two levels. The V02 max is reported on the display and the maximum workload contained in

the report, available only if the optional external printer is installed.

performance:

- Instruct subject about the protocol and adjust the chest belt for reliable pulse.
- Select YCMA protocol.
- Setup subject age, maximum heart rate, weight and sex according to menu.
- Protocol operation may be terminated by depressing START/STOP (3).

The protocol will terminate automatically under two circumstances;

- 1) nine minutes (3 levels) have been completed, or
- 2) six minutes (2 levels) have been completed and the heart rate elicited by the first level was 110 bpm or more.

In addition, START/STOP may be used to end protocol operation after six minutes if the subject is having difficulty.

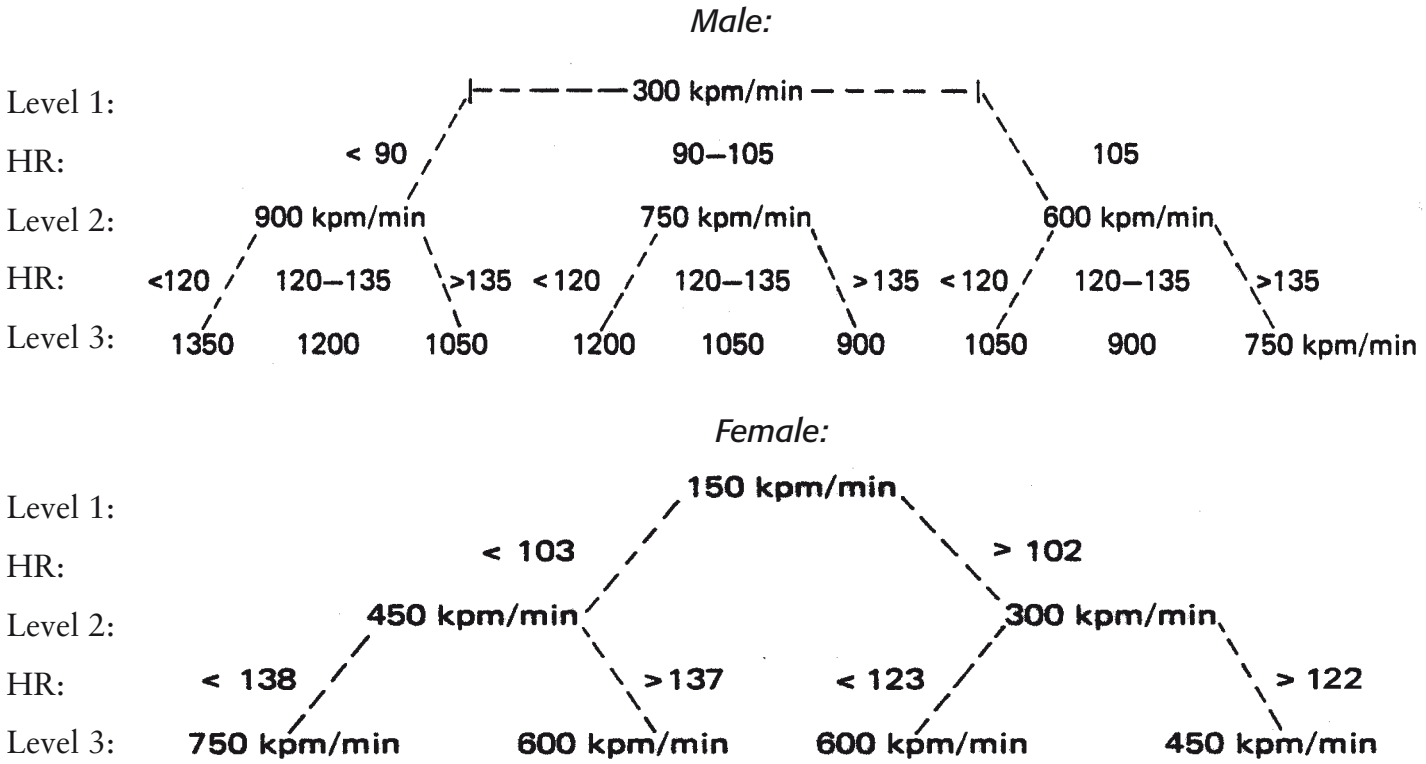

Note: Stated HR values are at the end of each level.

7.2.3 Bruce Protocol

Bicycle ergometers measure total oxygen consumption relatively independent of body weight. Since the subject's body weight is supported by the saddle, the total work performed is a function of only the resistive force and the pedal speed. At the same power setting, all subjects will have approximately the same oxygen consumption.

On the other hand, the treadmill measurement of oxygen consumption includes the subject's weight as a component of the total work and therefore measures oxygen consumption per kilogram of body weight. At a given incline and speed, each subject will have approximately the same V02 per unit of body weight.

The well known Bruce treadmill maximal oxygen consumption protocol has been converted for use on a bicycle ergometer, taking into account the differences between the treadmill and the bicycle devices. The ergometric workload is computed using the subjects body weight to calculate the total V02 at each stage of work, adjusting the power settings accordingly. The total oxygen

consumption is calculated from the V02 (ml/kg/min) for the stage multiplied by the body weight in kilograms. The workload is then selected from V02 workload table in the "Protocol Operation" section.

The protocol increases the workload every three minutes from warm-up stage to successively more difficult levels until the subject can no longer perform the test. At that time, the START/STOP key(3) is depressed to conclude the protocol. The protocol does end automatically if a subject is capable of completing Stage VII (79.9 ml/kg/min), an unlikely event.

The workload of the final stage is then converted to the equivalent V02 max and reported, both as total consumption in l/minute and per body weight in ml/kg/minute. If the subject has not completed at least one minute of the protocol has been completed at termination, a "Test Aborted" message is displayed.

The stages of the Bruce protocol are as follows:

Stage	Speed/mph	Grade %	V02 ml/kg/min
Warm up	1.7	5	12.2
Stage I	1.7	10	17.4
Stage II	2.5	12	24.8
Stage III	3.4	14	34.4
Stage IV	4.2	16	43.8
Stage V	5.0	18	56.7
Stage VI	5.5	20	68.2
Stage VII	6.0	22	79.5

The protocol will terminate automatically if Stage VII is completed. Normal termination is accomplished by depressing START/STOP(3) when the subject can no longer perform the work. If the subject has not completed at least one minute at the final workload, the previous workload is used. If less than one minute of the protocol has been completed at terminal, a "Test Aborted"

message is displayed. The program automatically selects the current or previous workload, as appropriate.

Performance:

- Instruct subject about the protocol and adjust the chest belt for reliable pulse.
- Setup subject age, maximum heart rate, weight and sex according to the menu system.

7.2.4 Naughton protocol

The standard Naughton Protocol (reference 5) is a two minute incremental test. The test is extremely similar to the Bruce protocol with two simple exceptions: the stages are two minutes in duration instead of three and the incremental $\dot{V}O_2$ between stages is linear (3.5 ml/kg/min). The stages represent discrete oxygen consumption levels generally referred to as “METS”.

The stages of Naughton protocol are as follows:

Stage	Speed/mph	Grade %	$\dot{V}O_2$ ml/kg/min
<i>Stage I</i>	2	0	7.0
<i>Stage II</i>	2	2.5	10.5
<i>Stage III</i>	2	7.0	14.0
<i>Stage IV</i>	2	10.0	17.5
<i>Stage V</i>	2	14.0	21.0
<i>Stage VI</i>	2	17.5	24.5
<i>Stage VII</i>	3	12.5	28.0
<i>Stage VIII</i>	3	15.0	31.5
<i>Stage IX</i>	3	17.5	35.0

The operation of the protocol is otherwise identical to the Bruce protocol.

Performance:

- Instruct the subject about the protocol and adjust the chest belt for proper heart rate.
- Then follow Naughton menu.

7.3 Menu 2: Manual/ Work test

7.3.1 Manual use

Begin to put in personal data like sex, weight, age and max. heart rate.

Workload - Force setting

The workload can be set in Newtons(N) or kp. Power is in this mode depending on the pedal rpm.

Workload can be increased or decreased with keys 7/4, 8/5 and 9/6.

- Key 7/4, increase / decrease step 1.00 kp or 10 N
- Key 8/5, increase / decrease step 0.10 kp or 1 N.
- Key 9/6, increase / decrease step 1.00 kp or 0.1 N.
- Press start/stop when finished.

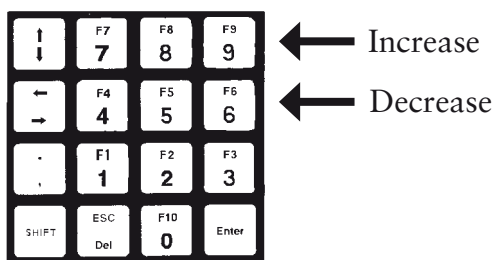

Workload - Power setting

Power level can be set in watts or kpm/min. Power level is not depending on pedal rpm.

- Key 7/4, increase/decrease step 100 watts or 100 kpm/min.
- Key 8/5, increase/decrease step 10 watts or 10 kpm/min.
- Key 9/6, increase/decrease step 1 watts or 1 kpm/min.
- Press start/stop when finished.

Workload - VO2

This is also a type of power setting. The advantage in this mode is that the workload can be set in ml/min/kg which means that the power is related to the subjects bodyweight. A certain level of ml/min is always the same as a given power level. See table in chapter "Testing - general".

- Key 7/4, increase/decrease step 10 ml/min/kg or 1 l/min.

- Key 8/5, increase/decrease step 1 ml/min/kg or 0.1 l/min.
- Key 9/6, increase/decrease step 0.1 ml/min/kg or 0.01 l/min.
- Press start/stop when finished.

Workload - HR related <BPM>

The Heart Rate program is designed to adjust the workload in an attempt to maintain a desired heart rate. This is achieved by increasing the workload from zero, at the start, using incremental steps. How fast the power is adjusted is depending on how far away the actual heart rate is from the desired heart rate.

At heart rate lower than the desired setting the workload will increase with 60W (375 kpm/min) per minute until the subjects heart rate is higher than 75 % of the desired heart rate. The power will then increase at 30 watts (180 kpm/min) per minute until the actual heart rate is within 5 bpm from the desired value. The power is kept at a constant level as long as the subjects heart rate is within +/- 5 bpm from the programmed heart rate value. The work test continues until the it is stopped by the start/stop button (key 3).

The target heart rate is entered as part of the test preparation. Default value is 120 bpm. The target training rate may be changed to suit the training program by just entering the value on the keyboard.

- Key 7/4 increases/decreases 100 bpm.
- Key 8/5 increases/decreases 10 bpm.
- Key 9/6 increases/decreases 1bpm.

NOTE: The maximum target heart rate that can be set is 90% of the calculated max. heart rate (220 - age).

The resultant workload which is determined by the computer to maintain the target heart rate, may be used as a basis for comparison over time, in an effort to objectively evaluate the effectiveness of training program.

Setup subject and follow menu.

Protocol operation may be terminated by depressing START/STOP key(3).

7.3.2 INCREMENTAL protocol

The incremental protocol consists of a series of workloads which are constantly increasing with time. Under control of the incremental, the ergometer exercises the subject to a maximum workload. The rate at which the workload rises can be preset.

The type of work: power or force may also be preset as desired. The incremental protocol may be used to create a linearly increasing workload test such as a modification of Naughton protocol. The Naughton may be viewed as an incremental protocol with a work type of V02 and a rate of 3.5 ml/kg/min every two minutes.

Set the subjects age, maximum heart rate, sex weight and selects the protocol.

Type of workload must be programmed. This stores the time and workload rate of change in continuous memory. Each step is calculated from the previous step plus the step time and step work, constantly increasing.

During executions of the protocol, the INCREASE and DECREASE keys (key 9 or 6) may be used to advance or retard the protocol. In this manner, if a workload is too easy, the protocol may be advanced in a non-linear fashion until the workload is as desired.

Instruct subject about the protocol and adjust the chest belt for reliable pulse.

Follow menu instructions and start test.

7.3.3 RAMP protocol

The ramp protocol is very similar to the incremental protocol in that it is based on a continuously increasing series of workloads. The major difference is that the ramp protocol steps are extremely fine, making the tension from one workload step to the next nearly imperceptible.

Ramp protocol are sometimes employed to provide a very rapid rise in workload in an attempt to determine the maximum workload which a subject can achieve without significant elevation in blood lactic acid from anaerobic metabolism. Due to the rapid rise in workload, there is little fatigue, although the medical risk may be high if an extremely high workload is attained too quickly.

Similar to the incremental, the ramp protocol must be programmed prior to running. The programming is slightly different in that the workload increase per minute is entered rather than the step time and step work increments.

Operation is similar as well, except that the protocol may not be advanced or retarded.

Instruct subject about the protocol and adjust the chest belt for reliable pulse.

Follow menu instructions and start test.

7.4 Menu 3: Sequence programs (user defined protocols)

The operator may custom design his own exercise protocols and store them in computer memory. This extra ordinary feature makes it possible to provide 10 additional protocols which may be setup as special purpose, readily available protocols. These protocols may be power or force type, time based designs. This flexibility enables the user to program several versions of the hills and valleys (increasing and decreasing workload) type of exercises and/or modifications to the Bruce/Naughton type protocols or different types of incremental work tests. The possibilities are virtually limitless.

Main menu;
3 Seq.programs
1 Execute, 2 Edit, 3 Exit

Make new program:

- Choose 3 "Seq. program" in the main menu.
- Choose 2 "Edit".
- Choose new program by just pressing Enter.
- The display looks as below.

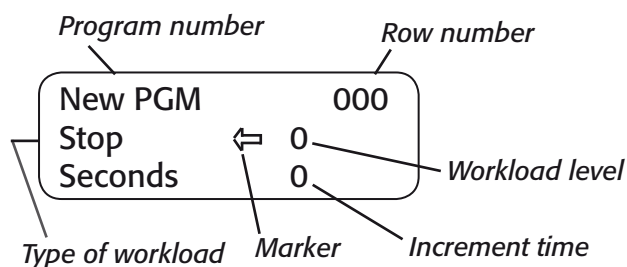

The marker (arrow in the display) indicates which position can be edited. When creating a new program begin to change "stop" to desired workload. This is done by the keys 1 - 5.

Key 1 = Newton, key 2 = kp, key 3 = watts, key 4 = kpm/min and key 5 = ml/kg/min. Key 0 = Stop which is used to end the program.

Example:

Choose i.e. kp (key 2) and press Enter. The marker turns to the right where workload level can be set. Type say 1.5 and Enter. Marker moves to position seconds. Enter say 300 (=5 minutes). Marker moves up and indicates row number. Press Enter and number increases automatically one step. Marker moves to type of workload again. The same as before is set by just pressing Enter. A change can be done by pressing key 1-5 until the right type of workload shows up and then press Enter. Marker moves to workload level. Enter

level, Enter seconds a.s.o. until the program is long enough.

When the program is to be finished move the marker to point at type of workload and change with key 0 which is Stop and then press Enter. Programming is finished and program number (0 - 9) must be Entered. Back to menu again.

NOTE: If a figure already containing a program is used this will erase the old program.

Edit an existing program:

Press 2 = Edit.

Choose program number. Step through the program with the Enter key and make desired changes. Then go to workload setting and change to Stop (key 0) and then press Enter.

NOTE! After editing an old or new program turn off the computer for correct download of data.

Execute program:

Begin with 3 Seq. programs in the main menu and then 1Execute. Choose an existing program and press Enter.

It is recommended to have a note about different program types and numbers. However it is possible to take a look in advance at a program. Do as under "Edit an existing program". If it says "stop" in work load position there is no program stored under that number. Use ESC key and try with a new number.

7.5 Menu 4: Analog control

Instructions how to connect an external ECG device with analog control.

1. Get the correct analog cable for the ECG device in use.
2. Connect the cable to the output for analog control on the ECG equipment.
3. Connect the other end of the cable to the analog input on the Ergomedic 839E.
4. Switch on power for the External equipment and the Monark Ergometer.
5. Start the analog control program on the external device and set a power that corresponds to a voltage of minimum 2.5 Volt (normally corresponding to 250 watts). This has to be done to be able to calibrate the power setting on the bike with the signal that comes from the External device.
6. Push '99' on the handheld unit. You will then come to the service menu.
7. Then push '8' – Set analog.
8. Choose '3' – Watts. If the analog signal from the External device has not been set to earlier indicated signal level the display will show as follows:
Input signal low
- below 2 V.
Can not adjust. Push Enter.
If this is the case – start again from point 4.
9. On the 839E handheld display the following will show up:
 Choose analog
 - Watt
 -
 Put in the corresponding Watt value from the External device and press 'Enter'. The display will now return to the Service menu.
10. Press '0' – Exit – to get back to the main menu.
11. Press '4' – Analog control. The display will now show in line three the power in Watts, that corresponds to the power which is set on the External device.

When setting up the Ergomedic 839E next time you only need to push '4' – Analog control – since the set up already is saved in the memory of the bike

7.6 Menu 5: Calibration

Under menu 5 you calibrate the electronics. For further instructions see chapter "5.4 Calibration electronics".

7.7 Menu 6: System

Menu options:

- 1 Setup
- 2 Language
- 0 Exit

1) Setup

- Pedal ref.: Metronome setting
Default setting <65> rpm.
- Pulse alarm: on/off
- Optical pulse: on/off
- Optical metronome: on/off
NOTE! If both opti. pulse and optic metro. are set to on only optic pulse will be set to on.
- Print report: on/off
Test report to printer.
When running fixed protocols the printer is automatically set to on.
- Weight unit: Can be set to
0 = kg, 1 = pounds
- Distance unit: Can be set to
0 = km, 1 = miles
- Logg interval: Time delay for every printout row,
1 - 655 seconds can be set here.
Default setting <15> sec.

2) Language

- 1 English
- 2 Swedish

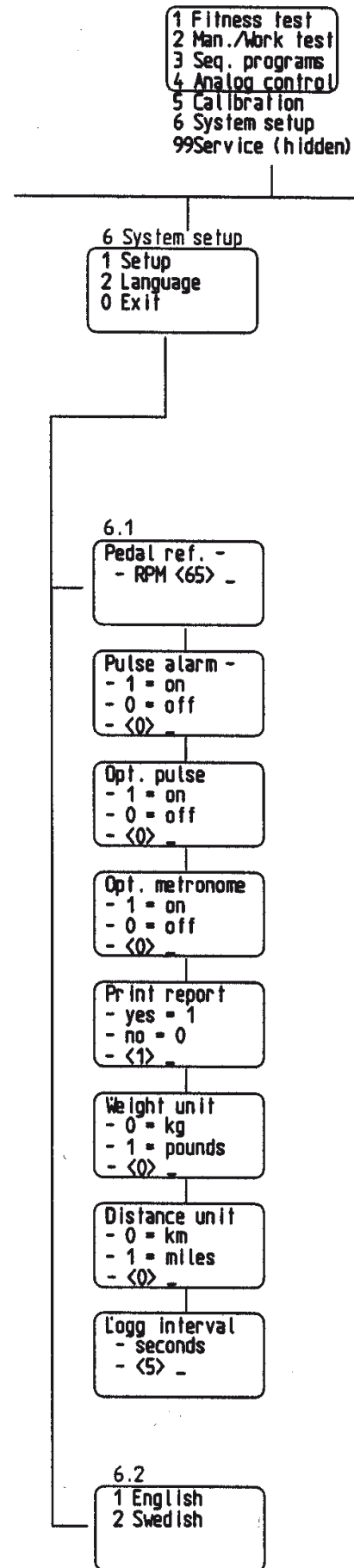

7.8 Menu 99: Service menu (hidden)

- 1 Adjust pot. (potentiometer)
If any service regarding the pendulum has been done the correct potentiometer position can be checked here.
Follow display instructions.
- 2 Calibrate pot. After adjusting pot. a calibration shall be performed here. Also after setting to default in the service menu a calibration has to be done here.
Follow display instructions.
- 3 Set to default Erases the memory. Formats and sets some data to default.
NOTE! A calibration must be performed after this action.
- 4 Printer
Form feed:
Line feed:
Page setting: Lines and margins can be set here.
Print report: To check printer connection.
- 5 Motor
Motor current limit.
Motor forward, backward and stop.
- 6 Service setup
Pedal ref.: Metronome setting

Pedal min.: Lowest pedal rpm to obtain workload on the bike can be set here.
Default setting is 30 rpm.

Cykelkonst.: This value can be adjusted so that the power on the bike can be corrected to the pedals or to the flywheel.
NOTE! In the Astrand test the power is calculated on the flywheel. Default setting is 1.00 which means there is no extra adjustment done for transmission loss. If for example setting is 1.04 this means that loss is calculated to 4%.

Max. accepted pulse deviation: This figure is the deviation allowed during steady state to calculate a test.
Default setting <5> bpm.

Weight unit: 0 = kg, 1 = pounds

Distance unit: 0 = km, 1 = miles

Opt. pulse: on/off

Opt. metronome: on/off

Sound pulse: on/off

Sound metronome: on/off

<BEL> pulse: on/off

<BEL> metronome: on/off

Pulse check: on/off

Command type: 0 Terminal/PC
1-3 See manual

- 7 LCD backlight Increase or decrease with left/right arrow key
- 8 Analog setup See "Technical Reference Manual".
- 9 Unlock NVM Fabric service

- 1 Fitness test
- 2 Man./Work test
- 3 Seq. programs
- 4 Analog control
- 5 Calibration
- 6 System setup
- 99 Service (hidden)

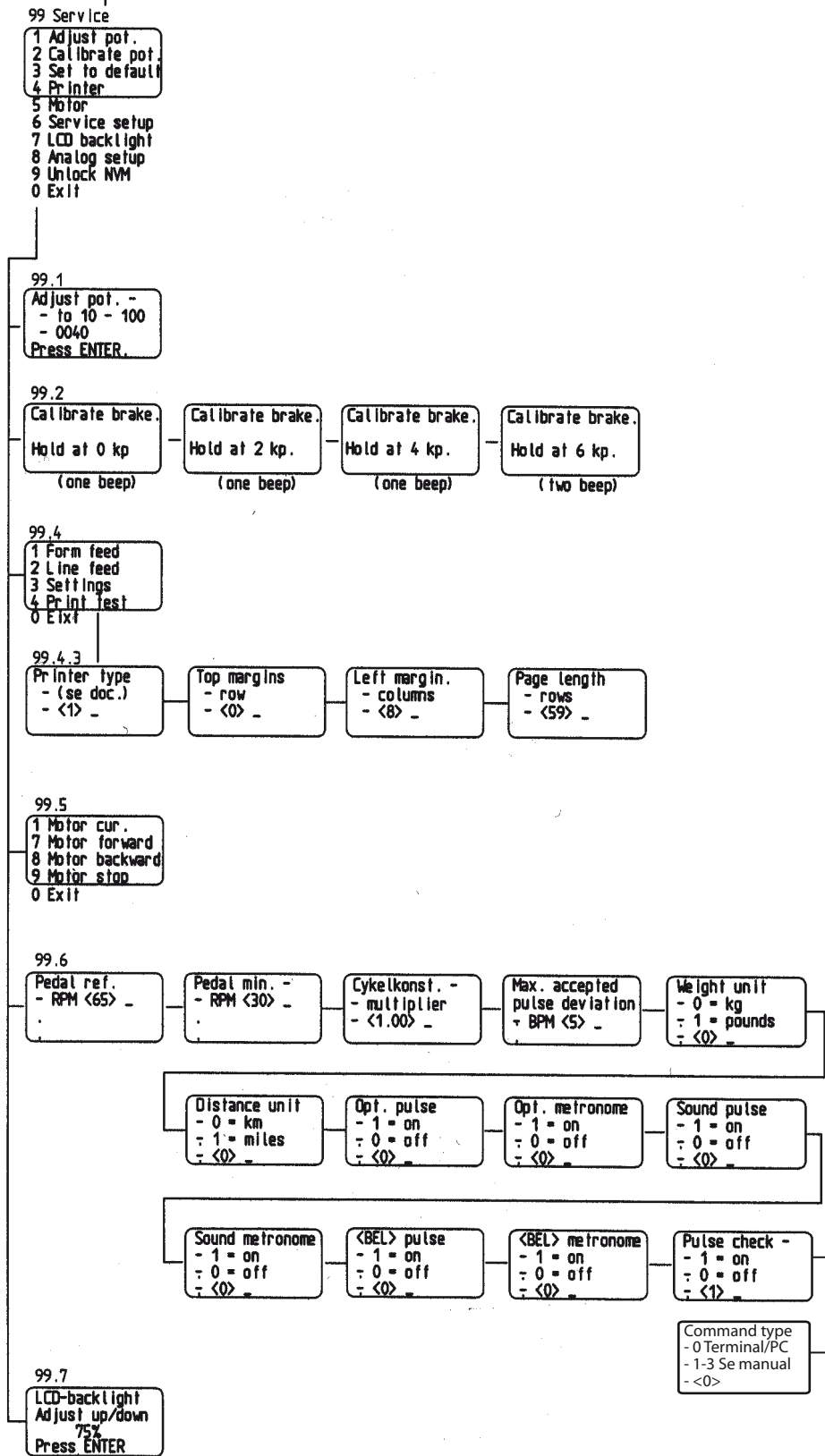

8 Service

8.1 Service check & maintenance

To keep your Ergometer in good shape you should make a regular service.

Service action	Approx time consumption	Suggested service interval
Keep your Ergometer clean and properly lubricated	5 min	once per week
Periodically wipe the surface with a rust preventative, especially when it has been cleaned and the surface is dry. This is done to protect the chrome and zinc parts as well as the painted parts.	5 min	4 times per year
Check now and then that both pedals are firmly tightened. If not the threading in the pedal arms will be damaged. Also check that pedal arms are firmly tightened on the crank axle, tighten if necessary. When the Ergometer is new it is important to tighten the pedals after 5 hours of pedaling.	5 min	4 times per year
Check that the pedal crank is secure to the crank axle.	5 min	4 times per year
Be sure that the pedals are moving smoothly, and that pedal axle is clear of dirt and fibers.	5 min	4 times per year
When cleaning and lubricating be sure to check that all screws and nuts are properly tightened.	10 min	2 times per year
Check that the chain is snug and there is no play in the pedal crank.	15 min	2 times per year
Check that pedals, chain and freewheel sprocket are lubricated.	5 min	2 times per year
Be sure that the brake belt does not show significant signs of wear.	15 min	2 times per year
Check that the handlebars and seat adjustment screws are lubricated.	5 min	2 times per year
Be sure that all moving parts as crank and flywheel are working normal and that no abnormal play or sound exists. (Play in bearings causes them to wear faster, shortening the life of the bike.)		Pay attention to any malfunctions, the faults must be addressed immediately before any further use of the bike.
Check that the flywheel is placed in the center and with plane rotation.		
Check that the washer for locking the saddle post is in place.		

8.2 Transport

At transport the tension device should be somewhat tightened to prevent the brake belt from falling off of the flywheel.

Fix the pendulum with a string or plastic tape.

8.3 Calibration of pendulum weight

Although all Ergometers are calibrated at the factory the user may wish to verify this by performing a mechanical scale calibration. If so please do the following.

Remove the cover from the flywheel. Loosen the balancing spring from the brake belt. Check that the 0-index of the scale is in line with the index of the pendulum weight. Adjust if needed. NB. Wait until the flywheel is not moving any longer.

Attach a known weight, e.g. 4 kg (our ref. No 9000-221) where the balancing spring was placed. Note: The weight should not be lighter than 3 kg, due to the possibility of inferior accuracy.

When correctly set, it should be possible to read this weight from the corresponding place on the meter panel.

Should there be a deviation, adjust the pendulum to the correct position on the scale by means of the adjusting weight. In order to change the position of the adjusting weight, loosen the lock screw of the weight.

Should the index of pendulum, weight be too low, move the adjusting weight upwards into the weight. Should the index be too high the adjusting weight is moved somewhat downwards and locked in the new position. This procedure is repeated until the correct reading is achieved.

Check the calibration of the pendulum weight once a year or when needed.

Assemble the front cover again.

8.4 Zero adjustment of meter panel

Move the pendulum to 4 kp and keep it there for a few seconds. Check that the belt is loosened. If adjustment is necessary, loosen first the lock nut(3) and then change the position of the meter panel (5), so that the board will have its 0-index in line with the index of the weight. Tighten the lock nut after the adjustment.

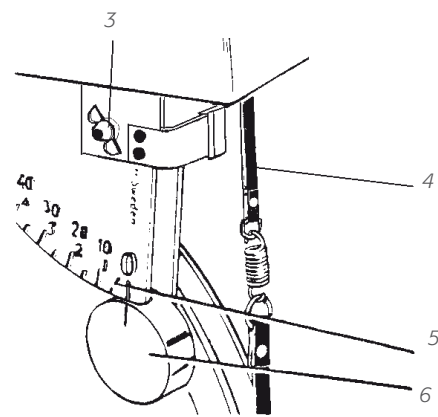
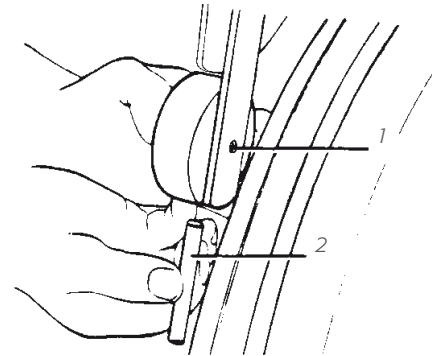
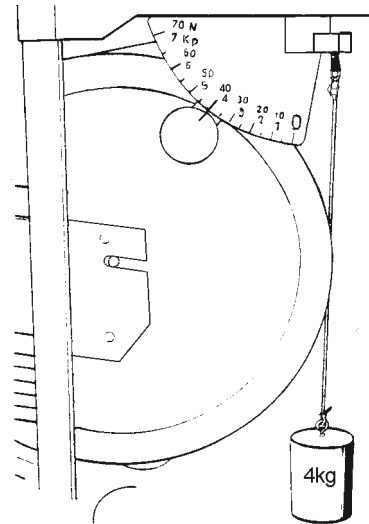

Fig: Calibration
 1) Lock screw
 2) Adjusting weight
 3) Lock nut
 4) Brake belt
 5) Meter panel
 6) Weight

8.5 Brake belt contact surface

The brake belt should be regularly checked to ensure that it has not suffered excessive wear. If it looks worn it should be replaced. Deposits of dirt on the brake belt and on the contact surface may cause the unit to operate unevenly and will also wear down the brake belt. The brake belt contact of the flywheel surface should then be ground off with fine sand paper and any dust removed with a clean dry cloth.

Remove left cover. Set the tension device to minimum load/tension. Take off the brake belt to the side. Grind with a fine sand paper. See *fig: Brake belt contact surface*. Grinding is easier to perform if a second individual cautiously and carefully pedals the cycle.

Irregularities on the brake belt contact surface are removed by means of a fine sand paper or an abrasive cloth. Otherwise unnecessary wear on the brake belt may occur and the unit can become noisy.

Always keep the brake belt contact surface clean and dry. No lubricant should be used. We recommend to replacing the brake belt when cleaning the contact surface. In regard to assembly and adjustment of the brake belt, see "Replacement of brake belt".

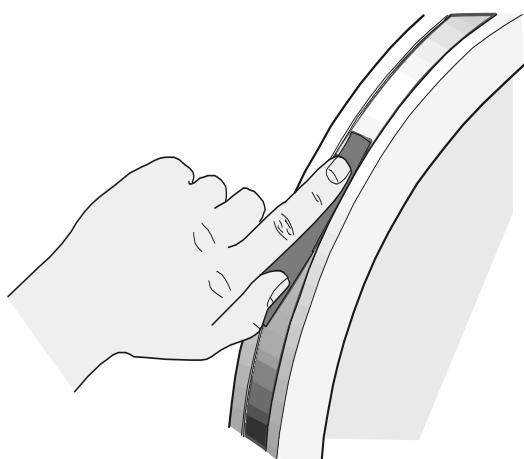

Fig: Brake belt contact surface

8.6 Replacement of brake belt

Loosen the brake belt at the spring (1). Loosen the screw (4 pcs) for the upper cover. Remove the cover.

Hold the pendulum above the 7kp marking so the screw for the fastening of the brake belt (2) can be loosened. Replace the brake belt and assemble the other parts in the reversed order according to the above.

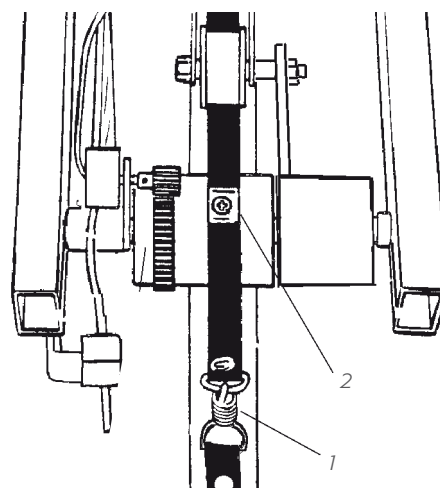

Fig: Brakebelt

1) Spring

3) Screw + washer

8.7 Pendulum weight bearing

The bearing in the pendulum weight are lifetime greased and normally require no maintenance. If a problem arises, please contact your Monark dealer.

8.8 Chain 1/2" x 1/8"

It is strongly recommended to keep the chain clean. Dirt build-up on the chain will cause excess wear. A chain lubricant and solvent for normal road bikes may be used.

Check the lubrication and tension of the chain in regular intervals. In the middle of its free length the chain should have a minimum play of 10 mm (1/4in). See *fig: Chain adjustments*. When the play in the chain is about 20 mm (3/4 inch) the chain must be tightened otherwise it will cause abnormal wear of the chain and chain wheels. Because of this it is always recommended to keep the chain play as little as possible. When the chain has become so long that it can no longer be tightened with the chain adjusters it is worn out and shall be replaced with a new one.

Loosen the lower chain guard bracket. Remove the screw for the right chain guard, back. To take away the chain guard, push it backwards. Take off the front chain guard, right and left side.

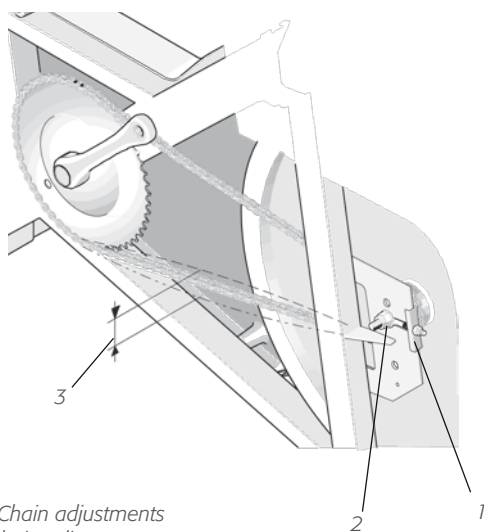

Fig: Chain adjustments
1) Chain adjuster
2) Axle nut
3) Chain play

To adjust the chain the hub nuts should be loosened. The hub and axle is then moved forward or backward by loosening or tightening the nuts of the chain tensioners. Tighten the nuts on the hub axle and the chain should be at the proper tension.

The spring of the chain lock should be assembled with the closed end in the movement direction of the chain. Use a pair of tongs for dismantling and assembling the spring.

NOTE: At assembly the flywheel has to be parallel with the centerline of the frame otherwise the chain and chain wheels makes a lot of noise and wears out rapidly.

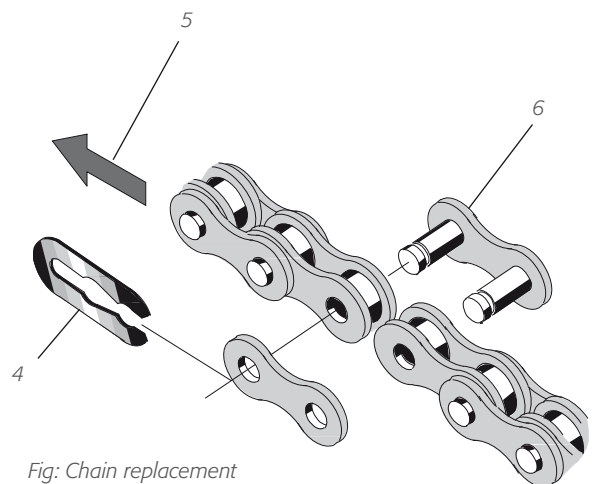

Fig: Chain replacement
4) Lock spring
5) Movement direction
6) Chain lock

8.9 Crank bearing

The crank bearing is long term greased and needs normally no supplementary lubrication. If problem arises, please contact your Monark dealer.

8.10 Freewheel sprocket

When replacing the freewheel sprocket remove the wheel cover. Loosen the brake belt at the belt tightener. Loosen the lower chain guard attachment. Take away the screw for the two chain on the right side and the front cover on left side. Loosen the saddle post screw some turns so the cover can be lifted up about 10 mm. To loosen the back chain guard, push it backwards.

Dismantle the chain as described in part "Chain 1/2" x 1/8" ".

Loosen the axle nuts and lift off the flywheel. Remove the axle nut, washer, chain adjuster and spacer on the freewheel side. Place the special remover (part No. 9100-14) in the adapter and place the spacer and axle nut outside. See *fig: Special remover*.

NOTE: Do not tighten the axle nut completely. It must be possible to loosen the adapter-sprocket half a turn.

Replace sprocket-adapter and assemble again in reverse order according to above points.

The sprocket should be lubricated with a few drops of oil once a year. Tolt the cycle somewhat to make it easier for the oil to reach the ball bearing. See *fig: Lubrication*.

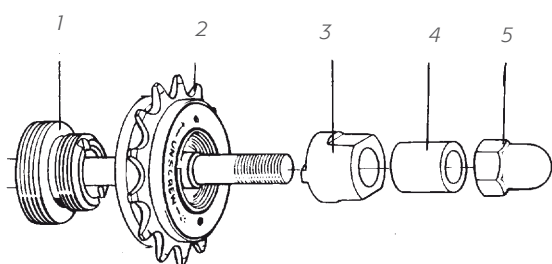

Fig: Hub assembly

- 1) Adapter
- 2) Sprocket
- 3) Remover
- 4) Spacer
- 5) Axle nut

8.11 Flywheel bearing

The bearings in the flywheel are lifetime greased and require normally no maintenance. If problem arises, please contact your Monark dealer.

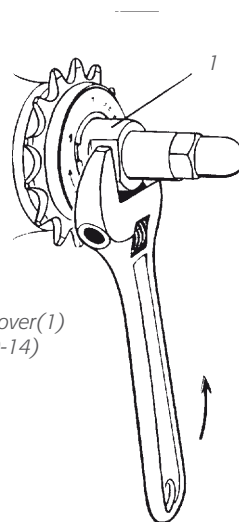

Fig: Special remover(1)
(part no: 9100-14)

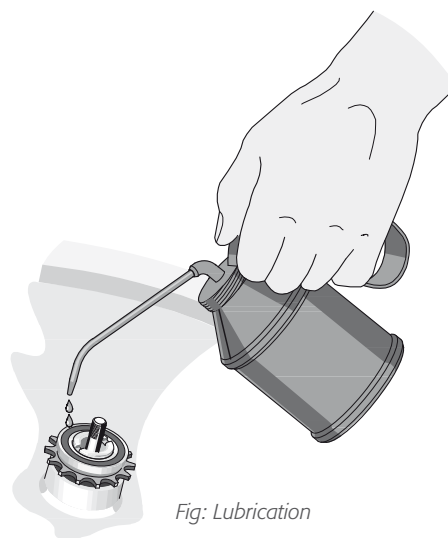
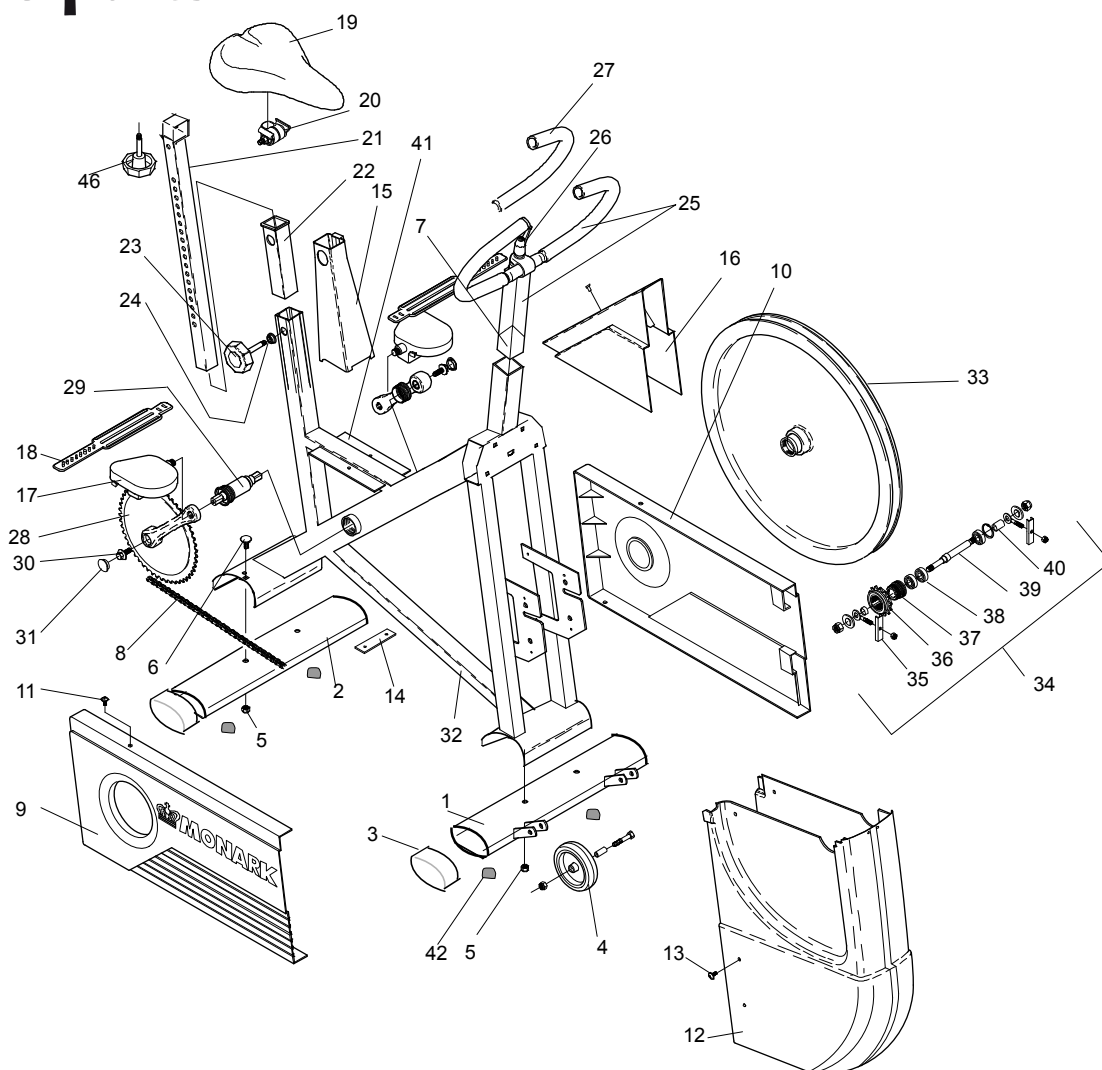
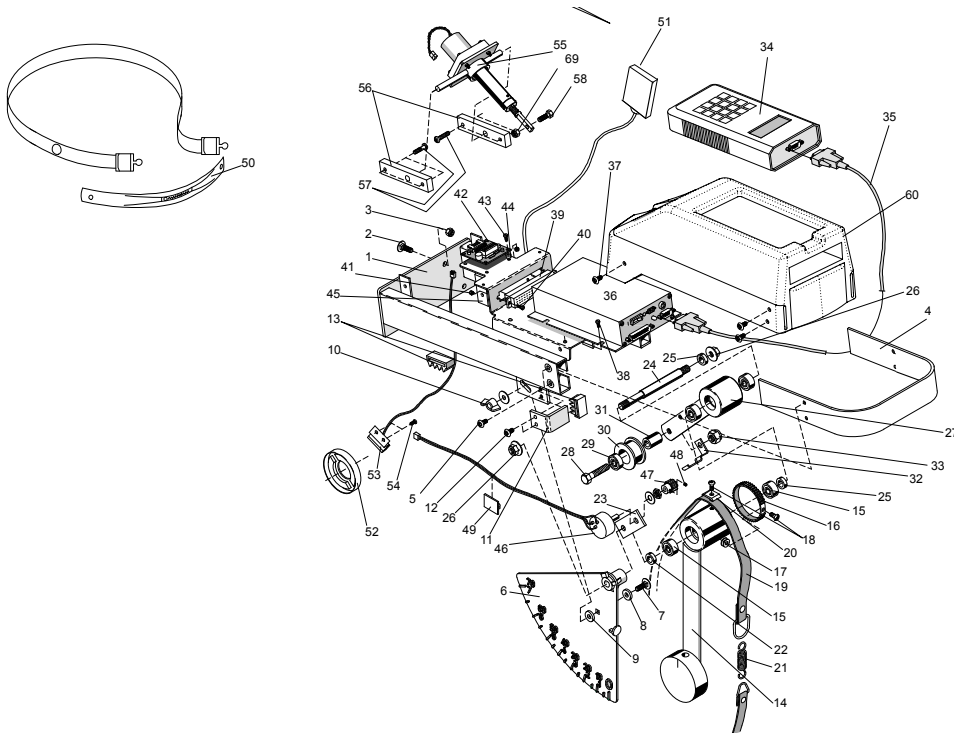

Fig: Lubrication

9 Spare parts



Pos.	Qty.	Art.No.	Description	Pos.	Qty.	Art.No.	Description
1	1	9301-15	Support tube, front	23	1	9300-118	Locking screw
2	1	9301-16	Support tube, rear	24	1	9300-134	Pressure washer, complete
3	4	9328-51	Plastic cap, blue	25	1	9300-280	Handlebar w steering stem
4	2	9000-37	Transport wheel, complete	26	1	9100-180	-Expander screw with lever
5	6	5845	Lock nut M8	27	1	9126-72	-Handgrip, blue (pair)
6	2	9300-12	Screw MVBF M8x16 mm	28	1	9300-430	Crank set complete
7	1	9300-291	Expander wedge M10	29	1	8966-175	BB cartridge bearing
8	1	9300-55	Chain 1/2 x 1/8", 116 l	30	2	8523-115	Screw M6S 8.8 M8 x 20 FZB
9	1	9300-50	Chain guard	31	2	8523-2	Dust cover
10	1	9300-52	Side guard	32	1	9301-5	Frame
11	2	5675-9	Mounting screw LKT-TT 5x6,5 mm	33	1	9300-3	Flywheel complete, 22 kg
12	1	9339-55	Wheel cover, front	34	1	9300-24	Wheel suspension compl. set
13	2	9304-32	Screw M5x25 mm	35	1	9000-12	-Chain adjuster (pair)
14	1	9300-53	Holder for guard	36	1	9106-13	-Sprocket
15	1	9300-56	Cover for saddle	37	1	9106-14	-Connection
16	1	9300-57	Cover for frame	38	3	19001-6	-Bearing 6001-2z
17	1	9300-220	Pedal, pair	39	1	9300-18	-Axle
18	1	9300-207	Pedal strap, pair	40	1	9300-17	-Bush, 23 mm
19	1	4994-5	Saddle	41	2	9300-58	Holder for chain cover
20	1	5466	Saddle bracket	42	4	9328-26	Rubber foot
21	1	9300-138	Saddle post		1	9000-211	Calibration weight, 4 kgs
22	1	9300-115	Bush				



Pos.	Qty.	Art.No.	Description	Pos.	Qty.	Art.No.	Description
1	1	9339-38	Frame for equipment	34	1	9339-51	Handheld controller
2	4	9300-21	Screw MVBF 6x16 mm	35	1	9339-27	Communication cable
3	4	5843-9	Nut M6	36	1	9339-52	Base unit
4	1	9339-59	Handle	37	6	5673-9	Screw M5x12
5	4	5673-9	Screw M5	38	4	5675-9	Screw M5x6,5
6	1	9339-100	Meter panel	39	1	9339-25	Connection device
7	1	9339-21	Screw M6	40	2	9305-42	Screw MCS M3x30 fzb
8	1	5880	Washer	41	2	5840	Nut M3
9	1	5862	Washer	42	1	9339-56	Card for metronome
10	1	9000-102	Wing nut M6	43	4	9339-49	Screw MCS M3x10 fzb
11	1	9300-94	Stop	44	4	9339-33	Spacer
12	2	5671-9	Screw M5	45	1	9339-24	Cover
13	2	9300-99	Plastic stop	46	1	9339-62	Potentiometer
14	1	9300-88	Weight lever with ball bearing	47	1	9339-52	Pulley
15	2	19001-6	Ball bearing 6001-ZZ	48	1	9305-44	Screw
16	1	9303-54	Belt 55T	49	1	9300-66	Holder
17	2	5861	Washer	50	1	9339-98	Chestbelt DT
18	1	5673-9	Screw M5	51	1	9339-76	Receiver DT
19	1	9339-61	Brake belt	52	1	9300-671	Dust cover with magnet
20	1	9300-92	Bracket	53	1	9300-65	Crank sensor
21	1	9008-124	Spring	54	2	9326-59	Screw RXK B8x6.5 fzb
22	1	9339-87	Spacer	55	1	9339-57	Tension device complete
23	1	9303-51	Holder for potentiometer	56	2	9339-40	Bracket for tension device
24	1	9339-86	Axle	57	4	5671-19	Screw M5
25	2	9000-17	Spacer	58	1	14324-9	Screw M6
26	2	5799	Nut	59	1	5843-9	Nut M6
27	1	9339-22	Tension lever	60	1	9339-80	Instrument cover
28	1	14359	Screw M8		1	9339-67	Transformer (18V, 240W)
29	1	19088-6	Ball bearing		1	9339-66	Transformer (24V, 110-240W)
30	1	9100-21	Tension cylinder		1	9339-850	Chest belt Polar T34
31	1	9339-32	Spacer		1	9339-851	Starp for chestbelt Polar
32	1	9339-23	Belt control		1	9338-21	Receiver Polar
33	1	5844	Nut M8		1	9338-20	USB-serial adapter

10 Appendix

10.1 Operation interferences

It is normally considered that about 70% of all shutdowns on small computers is caused by mains interferences, i.e. at shot over voltage. These interferences can often be caused by different machinery, which is started or stopped. The processor in the computer is then reacting incorrectly or is not working at all. The problems can be solved by means of a mains interference protector, which is connected between the mains and the transformer.

10.2 Trouble shooting guide

Symptom	Probable Cause/Corrective Action
The Display is not working.	Check that transformer is plugged into proper voltage AC outlet and that the power connector is plugged into the 839 controller.
Display lights up but does not respond to keyboard.	Turn off power, wait 10 seconds and reapply power.
Does not load work	Check RPM (no force is applied if RPM is less than the pedal low ref.. Default 30 RPM) Check calibration
No heart rate	<p>Check the chest belt (battery). Wet the thumbs and place them on the electrodes. A low clicking sound will appear near battery lid while you click on the electrodes with one thumb.</p> <p>Use another external HR monitor to check the belt.</p> <p>Check that the chest belt is positioned correct on test person and tight enough.</p> <p>Check that the electrodes are wet, in hard cases it is necessary to use a contact gel or a mixture of water with a few drops of washing-up liquid.</p> <p>The level for HR signal can vary from person to person. Put chest belt on another known person who has a good pulse rendering.</p> <p>Check for no loose cables or jack if you have a plug-in receiver. Use another pulse receiver (pulse watch or test bike monitor) to check the chest belt.</p> <p>Check that it's the correct receiver and that it is placed correct. If it has a round Polar-sticker it should be placed straight.</p>
No RPM reading	Check cable.

Symptom	Probable Cause/Corrective Action
Unable to calibrate force	Potentiometer belt may be slipping or broken. Replace if damaged. Potentiometer misadjusted. Reboot memory from service menu (99). Set default (3).
Uneven Heart rate	Use an external unit for example a pulse watch to check if it also indicates irregular pulse. If it is the case there are probably disturbance in the room. Magnetic fields from high voltage cables, elevators, fluorescent tube etc can cause the disturbance. Other electronic equipment could be placed to close. If irregular pulse remains we recommend measuring HR manually. If HR still remains irregular at workload test person's health need to be examined.

10.3 Error messages

Message	Reason
<i>Test Aborted</i>	<i>An automatic protocol operation has been stopped prematurely. No results are available.</i>

10.4 References

1. Åstrand I, "Aerobic work capacity in men and women with special reference to age", Acta Physiol Scand. 49 (suppl. 169), 1960.
2. Åstrand P-O, "Experimental studies of physical working capacity in relation to sex and age", Munksgaard, Köpenhamn, 1952.
3. Åstrand P-O, Rodahl K, "Textbook of Work Physiology", McGraw-Hill, New York, 1970.
4. Bruce RA, Kusumi F, Hosmer D, "Maximal oxygen intake and nomographic assessment of functional aerobic impairment in cardiovascular disease", Am Heart J 85:546-562,1973.
5. Naughton J, "Exercise Testing and Exercise Training in Coronary Heart Disease", Academic Press, New York, 1973.
6. Golding LA. Myers CR, Sinning WE, "The Y's way to physical fitness" YMCA of the USA, Rosemont, IL, 1982.
7. Wilson PK, Bell CW, Norton AC, "Rehabilitation of the heart and lungs", Beckman instruments, 1980.
8. Åstrand P-O, "Ergometri - konditionsprov", Monark, Sverige.